

Zawias z trzpieniami i tulejami gwintowanymi

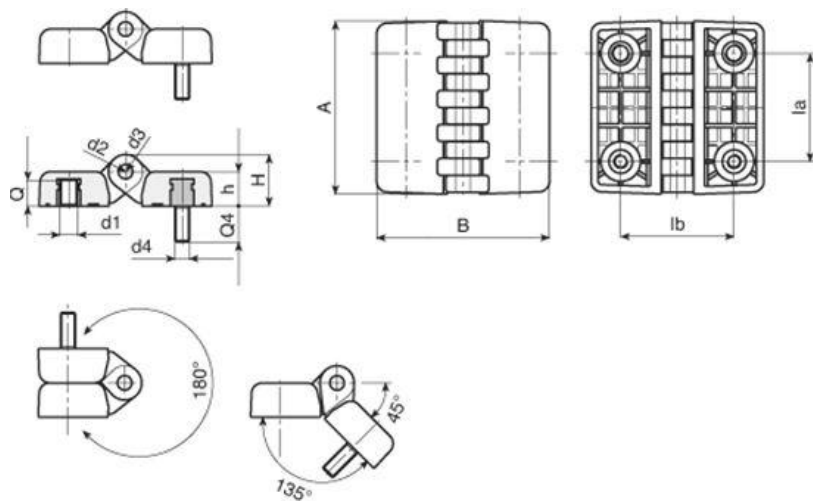

Symbol	la	lb	A	B	h	H	d2	d3	d1-d4	Q	Waga (g)	F1 (N)	F2 (N)
392.001	30	30	48	48	10,5	15,5	5	10	M5	7	15	40	1850
392.002	30	30	48	48	10,5	15,5	5	10	M6	7	15	41	1850
392.003	40	40	64	64	13	19	5	12	M6	9	20	73	4000
392.004	40	40	64	64	13	19	5	12	M8	9	20	85	4000
392.005	60	63	95	95	19	28,5	8	18	M8	13	20	240	3100
392.006	60	63	95	95	19	28,5	8	18	M10	13	20	250	3100

- ➔ Materiał: poliamid wzmocniony włóknem szklanym odporny na oleje i smary
- ➔ Powierzchnia: matowa
- ➔ Kolor: czarny (RAL 9011)
- ➔ Łączenie: sworzeń ze stali ocynkowanej
- ➔ Trzpień: stal ocynkowana, gwintowany
- ➔ Tuleja: mosiądz, gwintowana, nieprzelotowa